



Integration with Autronic SMC SM2

PLXApp006 (V1.1) July 19, 2005

Summary

This application note outlines the procedures for R-Series/M-Series linear wideband output signal integration with the [Autronic](#) SM2 and SMA ECUs. Autotune feature will not function properly however, air/fuel ratio can be interpreted and data logged with this setup.

Connection Diagram

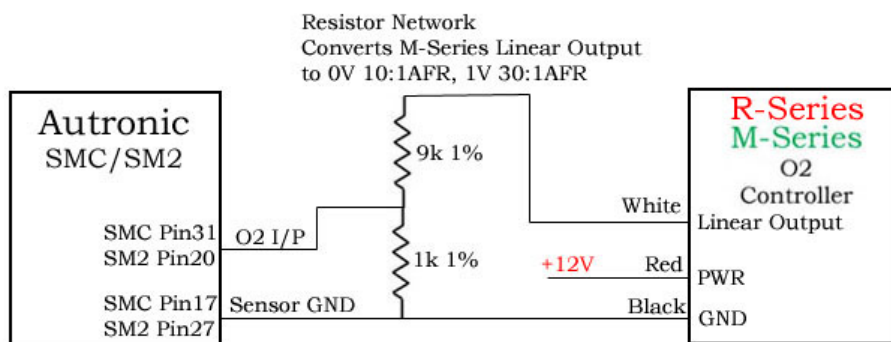

Software Setup

1. Start Up Autronic Auto Tune Software
2. Load *.Cal file
3. From the menu bar select M1 -> Engine Setup
4. Select A/F Sensor
5. Select Linear I/P A/F Meter Option

*Special Note: Readings between 20:1-30:1 AFR will be capped at 20:1 AFR.

Revision History

Version 1.0 (5/6/04)	Initial release
Version 1.1 (7/19/05)	Revised format to PDF Added R-Series support Comment on Autotune

PLXAPP006 (V1.1) July 19, 2005

www.plxdevices.com

(408)745-7591

